

SLZ-KA-VA Inverter Heat Pump

600x600 4-Way Blow Ceiling Cassette System

The SLZ-KA-VA series is perfect for both residential and small business applications, as it offers inverter technology alongside quiet operation. The compact size of this unit is ideal for 600 by 600mm ceilings and with a depth of 208mm, this lightweight unit makes installation a breeze. This unit also comes complete with a long life e filter that will last for approximately 2,500 hours.



Note: Optional interfaces for M-NET connectivity (MAC-399IF) and group control, fault/run (MAC-397IF) are available. Please see accessories / optional extras section.

Technical Information

SLZ-KA-VA - INDOOR UNITS		SLZ-KA25VA	SLZ-KA35VA	SLZ-KA50VA
MODEL REFERENCE				
CAPACITY (kW)	Heating (nominal)	3.0 (0.9-4.5)	4.0 (0.9-5.0)	5.0 (0.9-6.5)
	Cooling (nominal)	2.5 (0.9-3.2)	3.5 (1.0-3.9)	4.6 (1.1-5.2)
	Heating (UK)	2.5 (0.75-3.75)	3.3 (0.75-4.15)	4.15 (0.75-5.4)
	Cooling (UK)	2.5 (0.9-3.15)	3.45 (1.0-3.85)	4.55 (1.1-5.15)
SHF (nominal)		0.86	0.77	0.68
COP / EER (nominal)		3.61 / 3.62	3.64 / 3.30	3.23 / 2.82
ENERGY LABEL	Heating/Cooling	A / A	A / A	C / C
AIRFLOW (m ³ /min)	Lo-Mi-Hi	8-9-10	8-9-11	8-9-11
PIPE SIZE mm(in)	Gas	9.52 (3/8")	9.52 (3/8")	12.7 (1/2")
	Liquid	6.35 (1/4")	6.35 (1/4")	6.35 (1/4")
NOISE (dBA)	Lo-Mi-Hi	28-31-37	29-33-38	30-34-39
DIMENSIONS (mm) (grille)	Width	570 (650)	570 (650)	570 (650)
	Depth	570 (650)	570 (650)	570 (650)
	Height	208 (20)	208 (20)	208 (20)
WEIGHT (kg)	Unit	16.5	16.5	16.5
	Grille	3	3	3
ELECTRICAL SUPPLY		Fed by Outdoor Unit	Fed by Outdoor Unit	Fed by Outdoor Unit
PHASE		Single	Single	Single
FUSE RATING (BS88) - HRC (A)		6	6	6
INTERCONNECTING CABLE No. CORES		4	4	4
GRILLE REFERENCE		SLP-2AAW	SLP-2AAW	SLP-2AAW

SUZ-KA-VA - OUTDOOR UNITS		SUZ-KA25VA	SUZ-KA35VA	SUZ-KA50VA
NOISE (dBA) (Lo-Hi)	Heating/Cooling	46 / 46	48 / 47	53-55 / 51-53
WEIGHT (kg)		33	37	53
DIMENSIONS (mm)	Width	800	800	840
	Depth	285	285	330
	Height	550	550	850
ELECTRICAL SUPPLY		220-240v, 50Hz	220-240v, 50Hz	220-240v, 50Hz
SYSTEM POWER INPUT (kW)	Heating/Cooling (nominal)	0.83 / 0.69	1.10 / 1.06	1.55 / 1.63
	Heating/Cooling (UK)	0.76 / 0.55	1.00 / 0.85	1.41 / 1.30
STARTING CURRENT (A)		3.65	4.75	6.75
SYSTEM RUNNING CURRENT (A) [MAX] Heating/Cooling		4.0 / 3.4 [8.5]	5.15 / 4.95 [9.6]	7.0 / 7.4 [16.7]
FUSE RATING (BS88) - HRC (A)		10	10	20
MAINS CABLE No. CORES		3	3	3
MAX PIPE LENGTH (m)		20	20	30
MAX HEIGHT DIFFERENCE (m)		12	12	30
CHARGE R410A (kg) - 7m		0.9	1.05	1.6

INDOOR UNIT SLZ-KA25-50VA

Lower View >

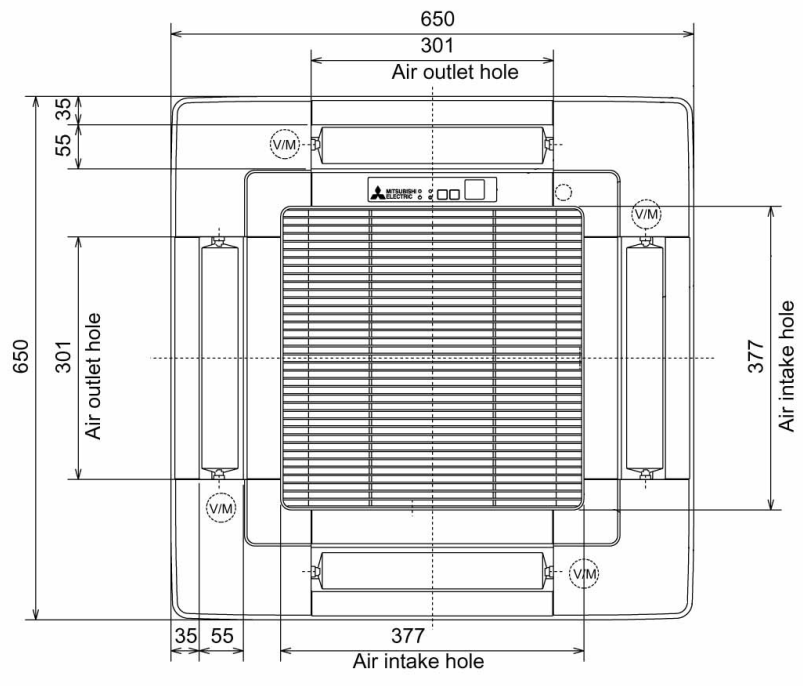

Side View >

